

# Hill

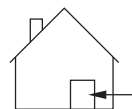

IP 20

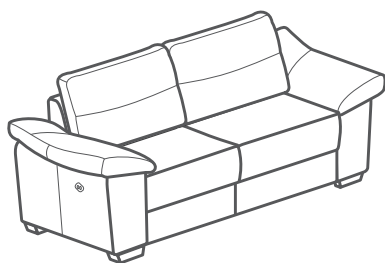
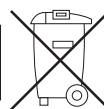

2,5 TVE

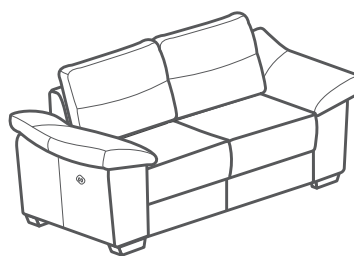

2 TVE



25min



1

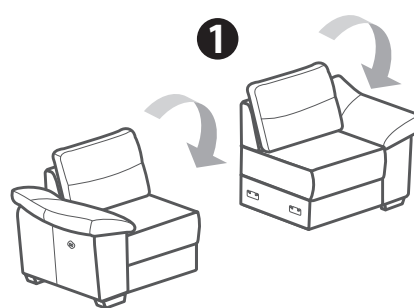
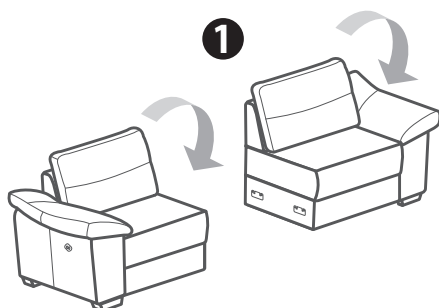

2

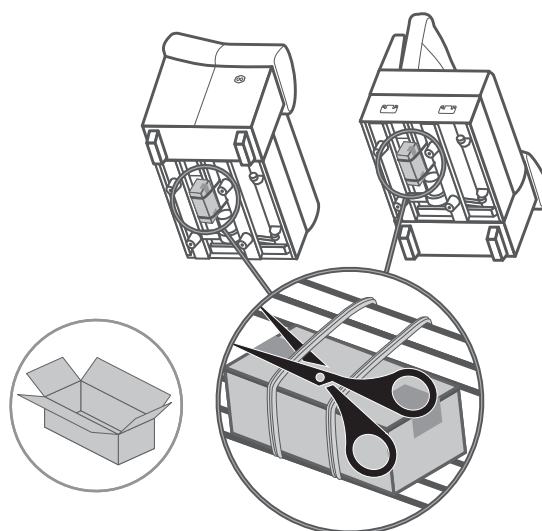
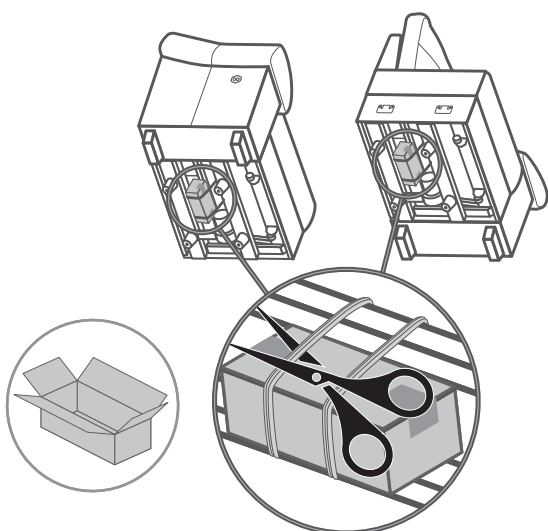

# Hill



3

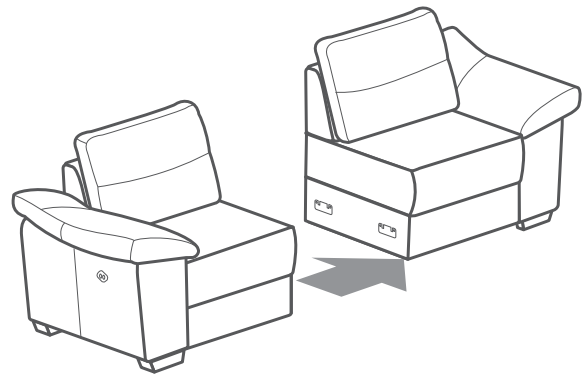
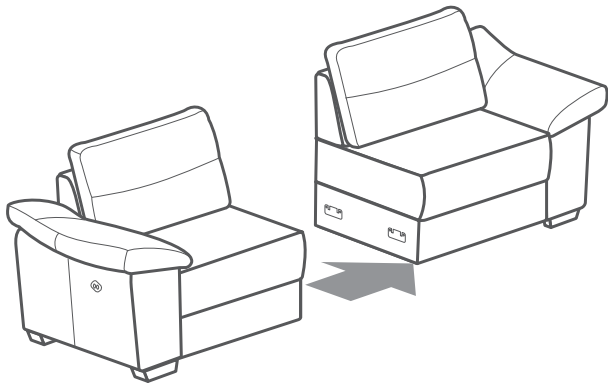

4

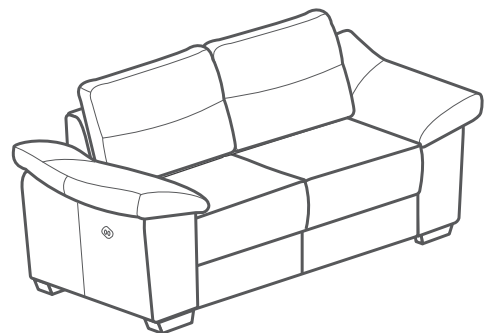
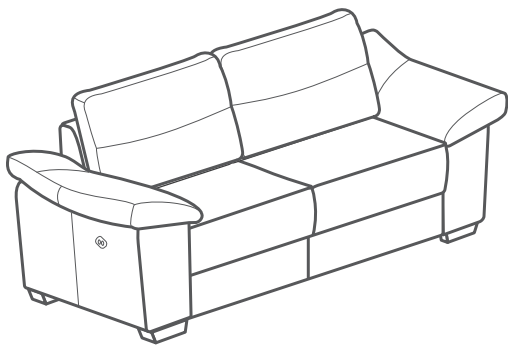

# Hill

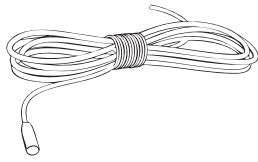

2pcs

A

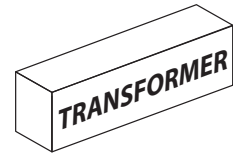

2pcs

B

## 5

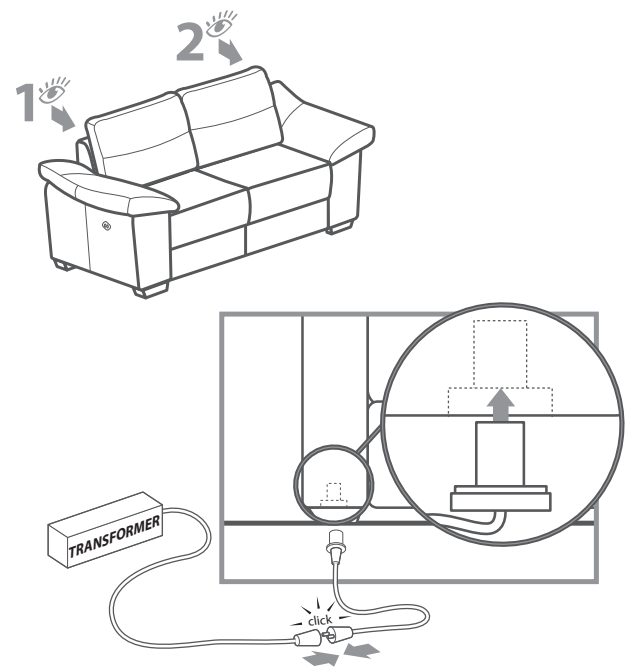
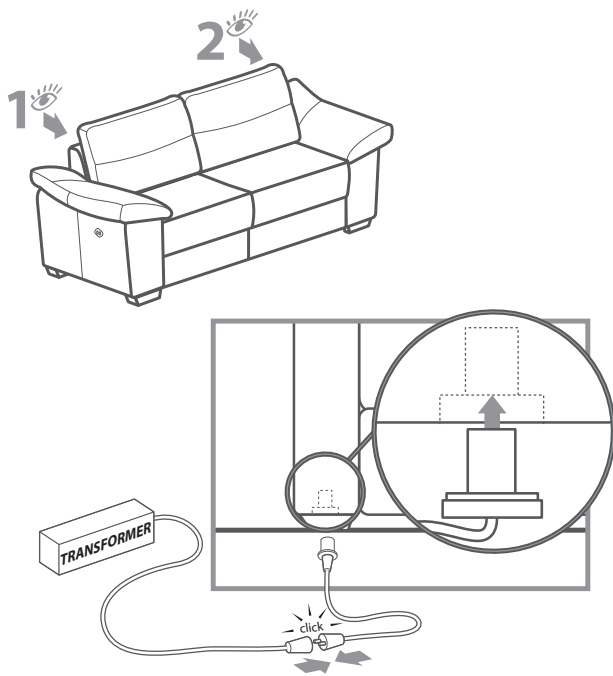

## 6

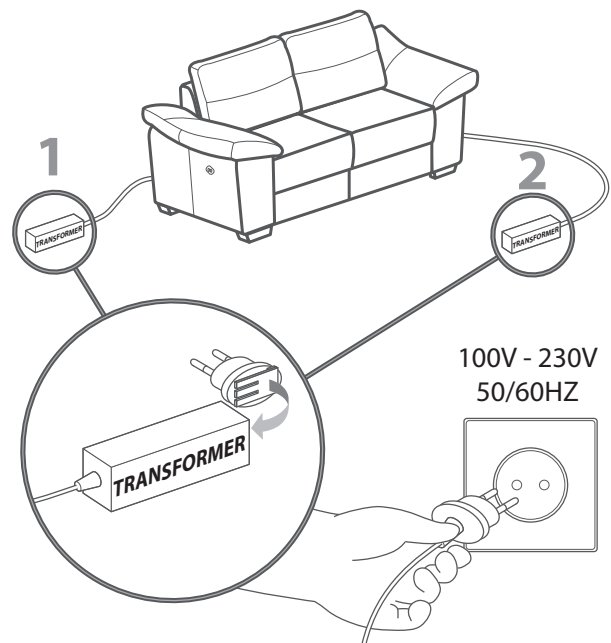
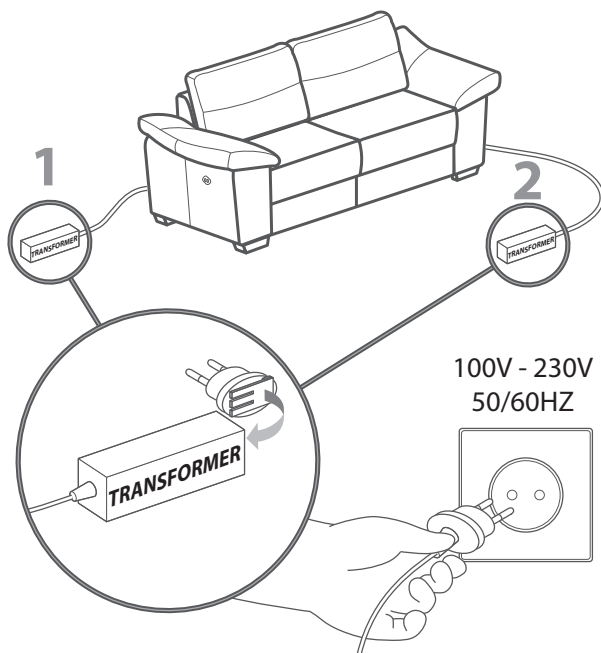



# Hill

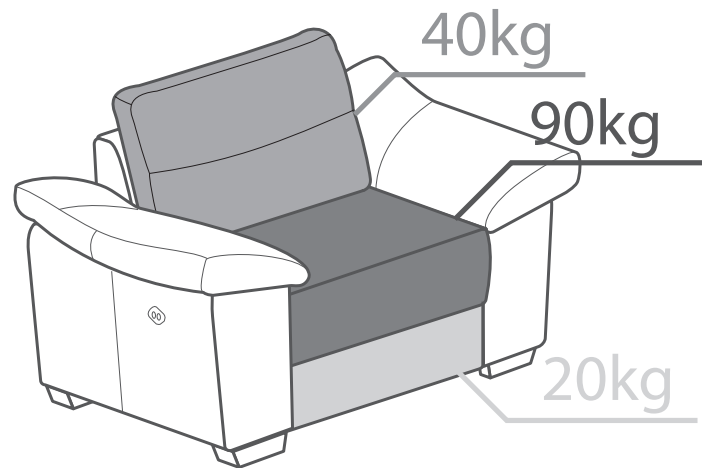
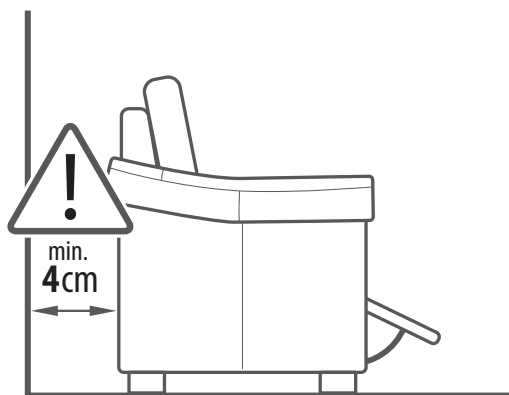
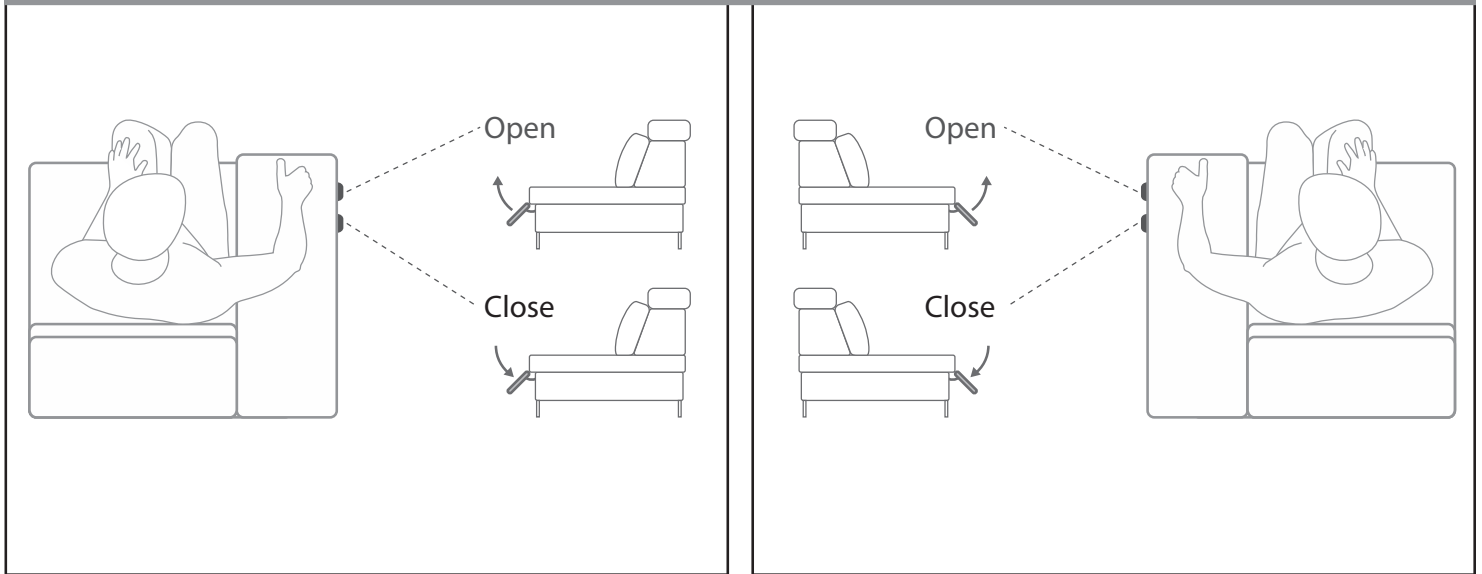

7



AC/DC Adapter  
Model No.: KE 1110030/MO-PS-1589  
Input: 100-240V~, 50/60 Hz, 1.5A  
Output: DC29V  $\text{---}$  1A  
Ta=40°C 70.2016  $\ominus$   $\oplus$   
Duty Cycle: 2min on/18min off  
Current Fuse: T2AL250VAC  
For indoor use only IP20     
Class 2 Power Unit  
Efficiency level  $\text{V}$   
GEMS  $\checkmark$  CEC  $\checkmark$  ERP  $\checkmark$   
SELV  $\checkmark$  RoHS  $\checkmark$  REACH  $\checkmark$

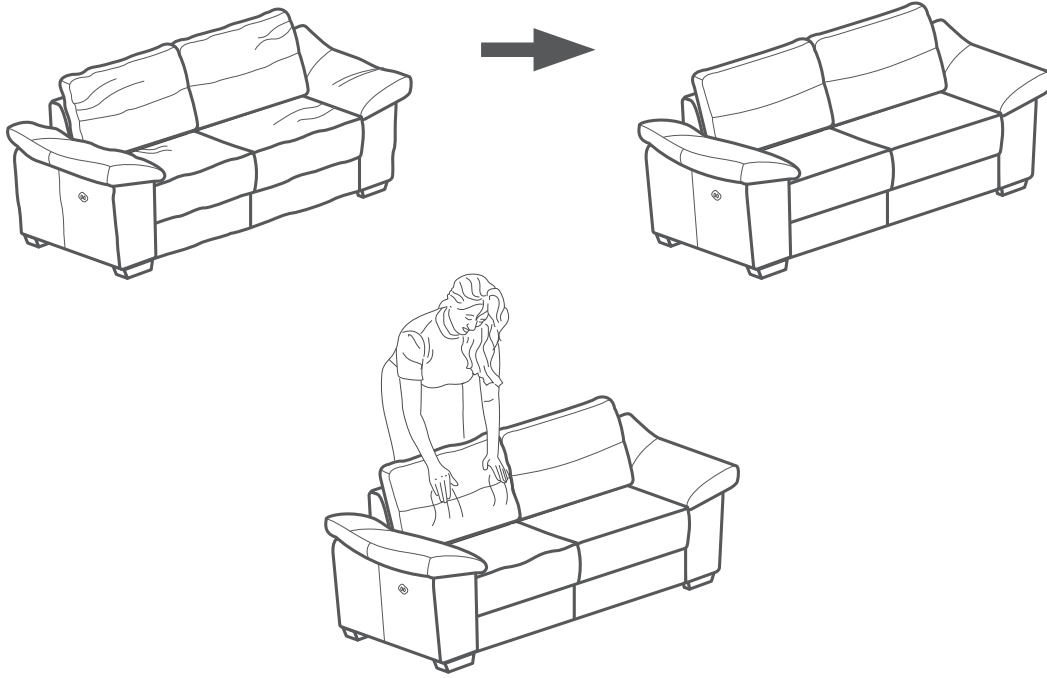

# WARNING

